

12 Series

Fast, compact single and double-spindle,
precision machining centers

Highly productive, compact and multifunctional

for the lowest cost per piece

Range of applications	[04–05]
Machine design	[06–07]
Extension options	[08–17]
Services	[18–19]



The CHIRON 12 series machining centers are among the best machines in their class in terms of speed, compact construction and versatility of use. 12 series machining centers can be supplied as single-, double spindle or MillTurn versions:

- Highly productive and reliable
- Highest precision and processing quality
- Minimum floor space requirements
- Fast set-up
- Simple operation
- High stability and dynamics
- Easy maintenance

FZ12 W
Machining center with tool-changing device 0°/180°, enabling loading and unloading during machining.



Due to its modular design and numerous configuration possibilities, every 12 Series machine can be assembled into a perfect individualized solution.

Your benefits: Workpiece production at the lowest cost per piece with the lowest tolerances and excellent surface quality.

Synchronized production quality

with perfection down to the smallest detail

▶ Range of applications	[04–05]
Machine design	[06–07]
Extension options	[08–17]
Services	[18–19]

Automotive

Complete machining of integral components, such as casing covers for water pumps made of aluminum [120 mm x 55 mm x 60 mm]

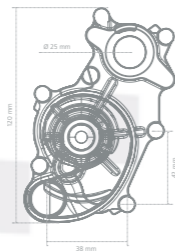

Medical

Bone plate made of titanium [110 mm x 48 mm 1.5 mm]

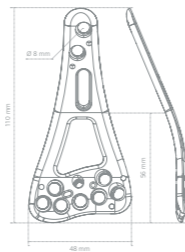

Machine construction

Milling, drilling, thread cutting and turning in one set-up for example, complex processing tools made of steel [130 mm x 43 mm]

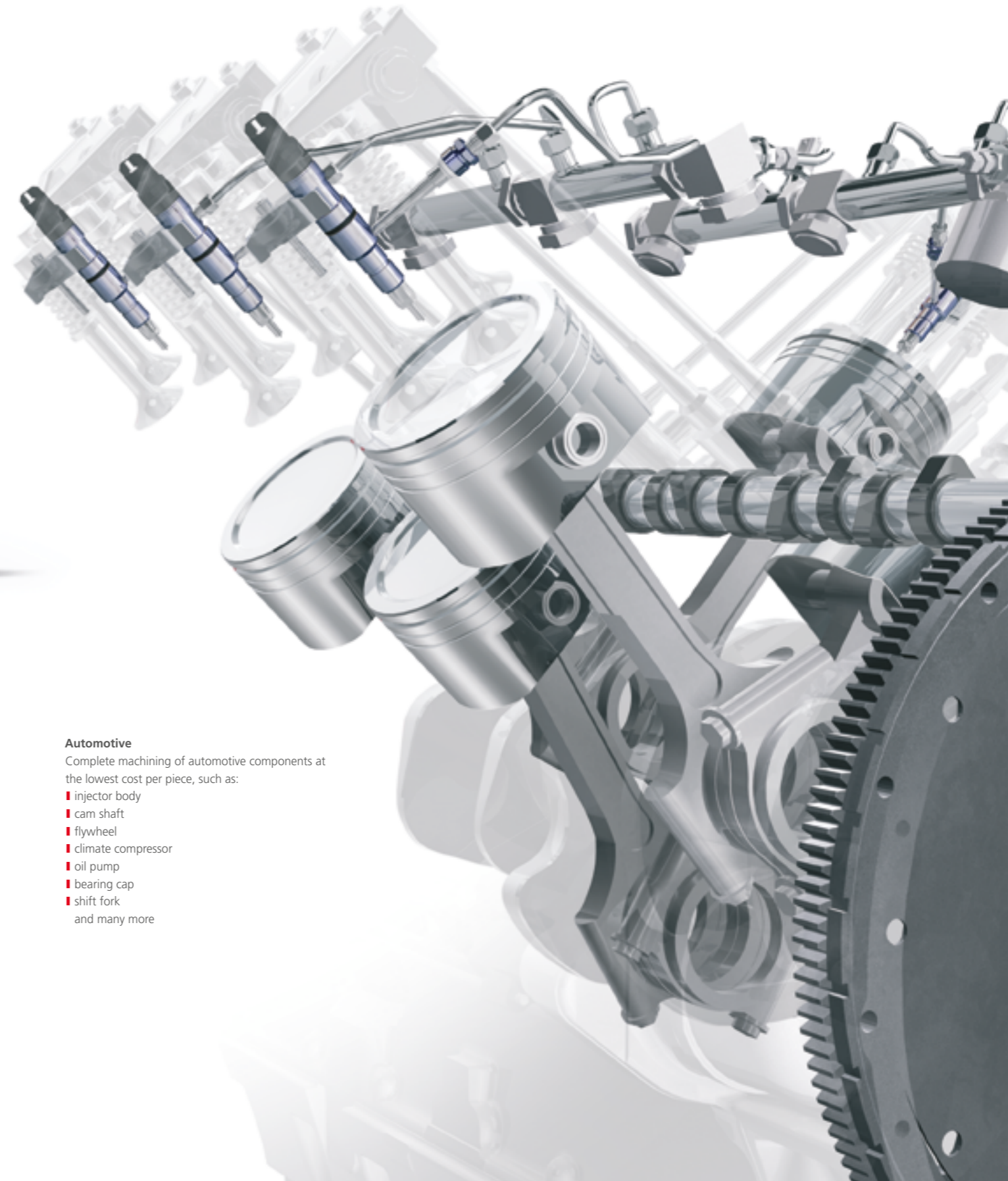
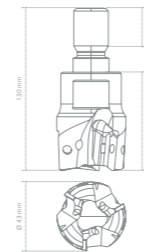

Medical

Angle head from brass for dental tools [50 mm x 15 mm]

We love perfection ...

That's why we view every detail as an exciting challenge. Whether automotive, aerospace, mechanical engineering, medical or precision engineering – the high-quality machining centers of the CHIRON 12 Series reduce processing times, produce excellent surfaces and compress your manufacturing process into the smallest space possible. 12 series machining centers are the perfect tools to implement your product ideas quickly and with micron-level precision.

Market leaders trust us.

Automotive

Complete machining of automotive components at the lowest cost per piece, such as:

- injector body
- cam shaft
- flywheel
- climate compressor
- oil pump
- bearing cap
- shift fork
- and many more

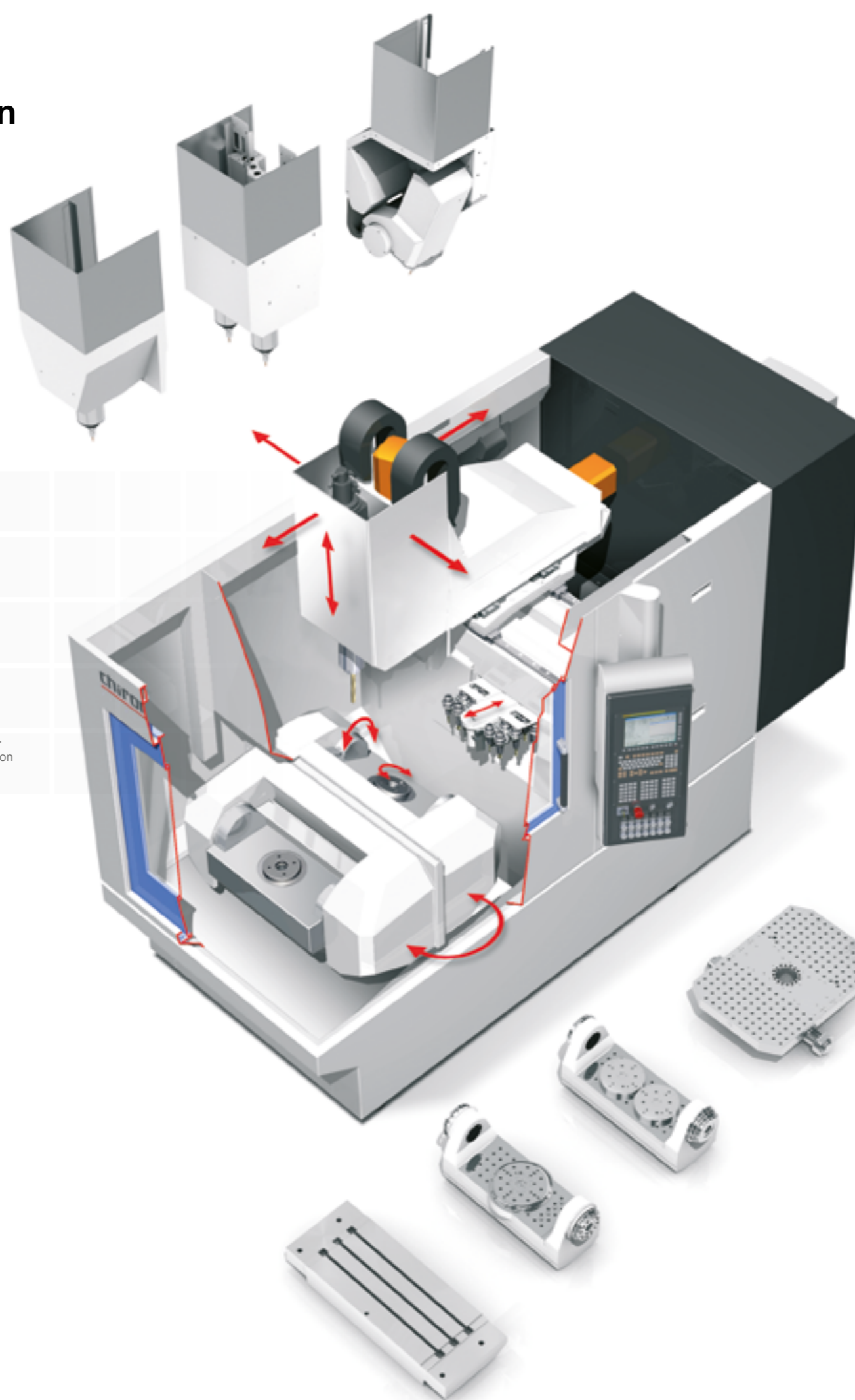

High-tech modules for any application

Perfectly balanced for greater flexibility



Range of applications	[04–05]
▶ Machine design	[06–07]
Extension options	[08–17]
Services	[18–19]

Spindles & spindle systems:

-  FZ: Proven single-spindle machining centers in the vertical traveling column design.
-  DZ: Highly productive double-spindle machining centers with spindle clearance 250 mm.
-  Machining centers with NC swivel head with infinitely programmable positioning in the range of -10° to +100°. Very robust, opposing pre-tensioned backlash-free precision gear with direct measuring system.

FZ12 W

Compact and fast single-spindle machining center with integrated workpiece changing device 0°/180° for easy loading and unloading during machining.

Tool changing systems:





-  Automatic tool change with the pick-up method (as fast 0.9 s) in single or double version for the provision of up to 128 tools (HSK 40 / HSK 50 / HSK 63).

Table options:

-  S: Fixed table with lots of space for devices or NC rotary table superstructures for multi-sided machining.
-  FX: 2-axis swivel rotary table with AC kinematics and one or two face plates (diameter: 1 x 280 / 2 x 245 mm) for single or multi-spindle multi-sided machining.
-  W: Workpiece changing device with table loading capacity of up to 300 kg per side and large clamping surfaces (2 x 660 x 350 mm), borehole pattern, central distributor for energy supplies.

Modular concept:

- Vertical traveling column principle
- Compact installation area from width 1.490 mm x depth 3.200 mm (S)
- Mineral cast machine bed
- High rigidity and thermal stability
- Motor spindles with water cooling
- Precision glass scales on all axes
- Dynamic direct drives and precision guides
- Robust CHIRON rotary axes
- Fully enclosed work area, stainless steel covers
- Smooth, steep walls for ideal chip flow directly into the chip conveyor
- Ergonomic operating and loading concept
- Service friendly access to all auxiliary units
- High durability, low maintenance

Highest precision: Glass scales and digital drive technology allow high acceleration with equally high contour accuracy.

The right machine for each component

Variants and extension options

Flexible work areas
and maximum paths
X=550, Y=400, Z=420 mm

Range of applications	[04–05]
Machine design	[06–07]
► Extension options	[08–17]
Services	[18–19]

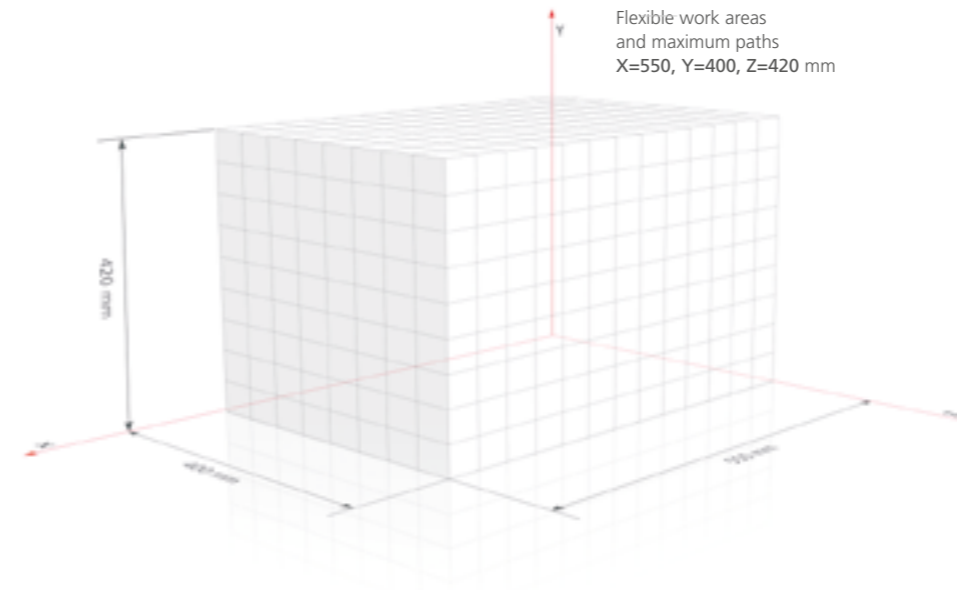

Spindles & spindle systems
Automatic tool changer
Table options

	S	FX	W	MT
FZ	FZ12 S	FZ12 FX	FZ12 W	FZ12 MT
DZ	DZ12 S	DZ12 FX	DZ12 W	
S-HEAD	FZ12 S			FZ12 MT



Process advantages:

- Maximum path [X–Y–Z] 550–400–420 mm
- Maximum electrical power 40 kW (40% ED)
- Spindle clearance DZ 250 mm
- Maximum spindle speed 40,000 rpm
- Chip-to-chip time starting from 2.2 s
- Maximum axis acceleration [X–Y–Z] 1–1.5–2 g
- Rapid feed as fast as 75 m/min
- Max. number of tools 128
- Tool taper HSK 40 / HSK 50 / HSK 63
- Maximum tool weight 5.0 kg
- Maximum tool diameter 125 mm
- Max. tool length 250 mm
- Automatic workpiece change from 2.0 s



FZ12 FX

Fast and compact precision machining center with a 2-axis swivel rotary table for 5-axis simultaneous and complete machining. Workpieces can be machined with high surface quality in one set-up.

DZ12 FX

Fast and compact double-spindle machining center with 2-axis swivel rotary table and two face plates. 5-axis simultaneous operations are carried out using high-performance control options.

FZ12 W

Machining center with automatic tool change using the pick-up method, and tool changing device (0°/180°) for loading and unloading during machining.

FZ12 MT

CHIRON MT: The fastest 6-sided complete machining with swivel head, turning spindle, turning revolver and opposed spindle for simultaneous milling and turning from bars.

Variety and flexibility as a foundation

Proven technology and the highest precision is our standard

Range of applications	[04–05]
Machine design	[06–07]
► Extension options	[08–17]
Services	[18–19]

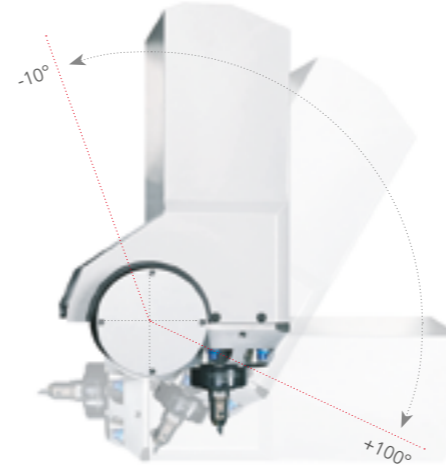

FZ12 S

Compact precision machining center with a fixed table and NC swivel head with infinitely programmable positioning (-10°/+100°).

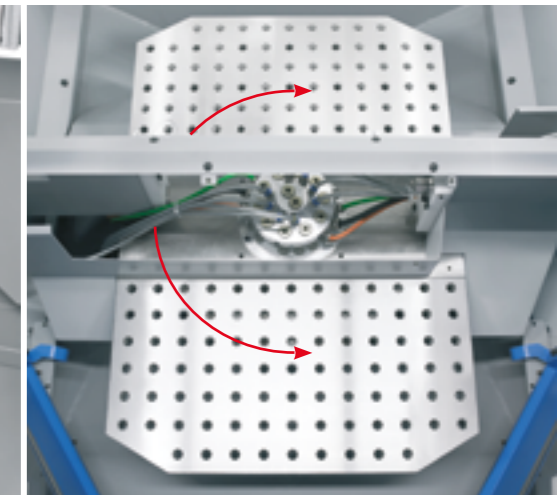
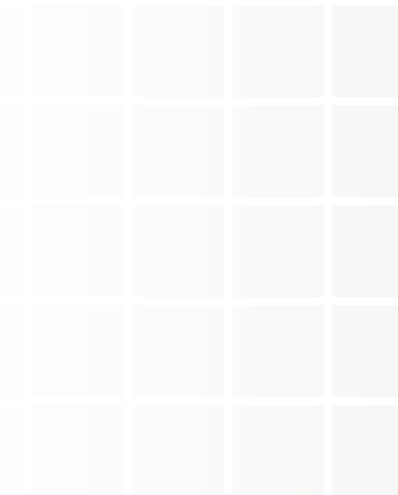
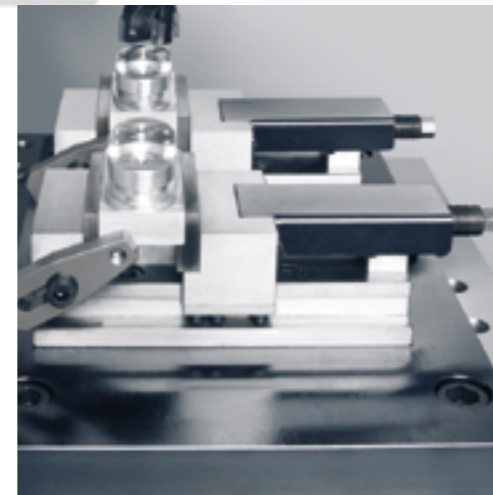

FZ12 S

Compact and flexible precision machining center with fixed table and automatic tool change. A lot of space for devices or NC rotary table superstructures.

FZ12 W

Machining center with automatic tool change using the pick-up method and tool changing device for loading and unloading during machining.

Workpiece changing device 0° / 180° with ample space for devices and NC rotary tables, such as the installation of a workpiece swivel device as the fourth NC axis.

Your advantages with the CHIRON fixed table or workpiece changing device:

- 3-axis basic machining center based on the vertical traveling column principle
- Compact installation area from width 1,490 mm x depth 3,200 mm (S) / 1,700 mm x 3,600 mm (W)
- Mineral cast machine bed
- High rigidity and thermal stability
- Clear, easily accessible work area
- Work area for larger workpieces or multiple set-ups
- Automatic tool change using the pick-up method
- Chip-to-chip time starting from 2.2 s
- Loading and unloading with tool changing device during machining (workpiece change time 2.0 s)
- Workpiece changing device with central splash guard and optimal accessibility
- Expandable to 4 axes with the basic device or to 5-axis machining with the 2-axis tilt rotary table
- Optional fully integrated automation solutions (Variocell)
- Machine tool construction "Designed and Made in Germany"

Precision in one set-up

Complete machining with CHIRON Five axis

FZ12 FX

Integrated CHIRON 2-axis rotary table, maintenance-free TORQUE drive technology and automatic tool change using the pick-up method.

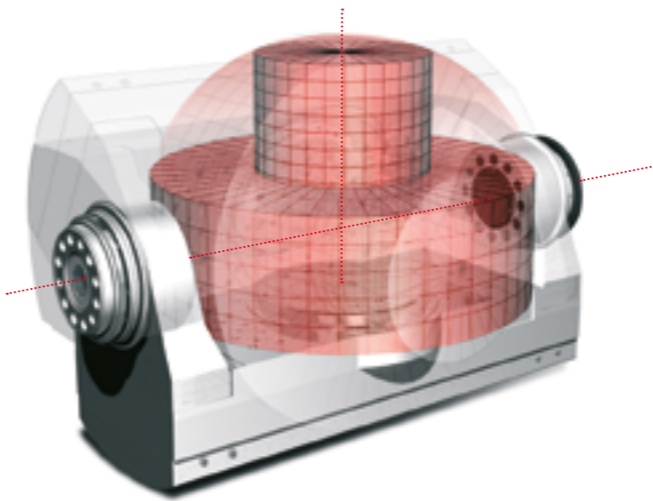

Max. workpiece dimension (FZ12 FX) swing diameter
 Ø 280 x 385 mm Ø 650 mm
 up to Ø 610 x 200 mm Ø 650 mm

Range of applications	[04–05]
Machine design	[06–07]
► Extension options	[08–17]
Services	[18–19]

DZ12 FX

Doubled productivity with minimal space requirements: fast double-spindle machining center with a 2-axis swivel rotary table (AC-kinematics) for efficient complete machining with five simultaneously controlled axes.



■ Spindle clearance 250 mm
 ■ 2-axis swivel rotary table CASD 280-2
 - Swivel range ± 120°
 - Face plates 2 x diameter 245 mm
 ■ Chain magazine / tool places 2 x 12 / 24 / 32 / 64
 ■ Tool change time 1.0 s

Five axis machining with the CHIRON rotary table program:

- robust and reliable technology – developed and made by CHIRON
- pre-tensioned, backlash-free precision gear with high overload capacity and high transmittable torque
- turning option due to precise torque technology

Your advantages with CHIRON FX:

- Compact installation area from width 2.100 mm x depth 3.200 mm
- Mineral cast machine bed
- High rigidity and thermal stability
- Highest precision in positioning and simultaneous operation
- CHIRON motor spindle speeds of up to 30,000 rpm
- Excellent surface quality
- Integrated CHIRON 2-axis swivel rotary table with direct measuring systems
- Integrated 6-way energy supply for clamping device on the face plate
- Zero-point clamping systems can be integrated
- Fourth axis with a pivoting range of up to +/- 120°
- 5th axis with TORQUE drive up to 1,000 rpm for turning work
- Automatic machine compensation due to the 3D touch probe TS27
- Optional fully integrated automation solutions (Variocell)
- Machine tool construction "Designed and Made in Germany"

Manufacture up to 75% faster with CHIRON multi-spindle processing

Range of applications	[04–05]
Machine design	[06–07]
► Extension options	[08–17]
Services	[18–19]



DZ12 W

Perfect combination of two spindles with workpiece changing device 0°/180°. (Figure: with NC rotary table and 4-fold clamping device for multi-sided machining).

DZ12 FX

Very compact and fast double-spindle machining center with a 2-axis swivel rotary table (AC-kinematics) for the efficient 5-axis complete machining.



The multiplier effect – more spindles, more cutting, more profit: The combination of 2 spindles and a 4-fold clamping device results in a cost saving of up to 50%. Doubled productivity on one machine means a reduction of machining time of nearly 50%. There is also the option of multi-side machining through NC controlled rotary axis.

Your advantages with CHIRON multi-spindle machining:

- Reduction of energy and space requirements
- Reduction of the total processing time
- Simplification of the material flow
- Reduced investment costs
- Reduced staff resources
- Water-cooled motor spindles up to 24,000 rpm
- Spindle clearance DZ 250 mm
- High rapid-feed speeds of up to 75 m/min
- Highest precision in positioning and simultaneous operation
- Precision glass scales on all axes
- Chip-to-chip time as fast as 2.2 s
- CHIRON 2-axis swivel rotary table possible
- Optional fully integrated automation solutions (Variocell)
- Machine tool construction "Designed and Made in Germany"

Simultaneous turning and milling

in the smallest work area, with CHIRON MillTurn

Range of applications	[04–05]
Machine design	[06–07]
► Extension options	[08–17]
Services	[18–19]



FZ12 MT

CHIRON MT: The fastest 6-sided complete machining with swivel head, turning spindle, turning revolver and opposed spindle for simultaneous milling and turning from bars.

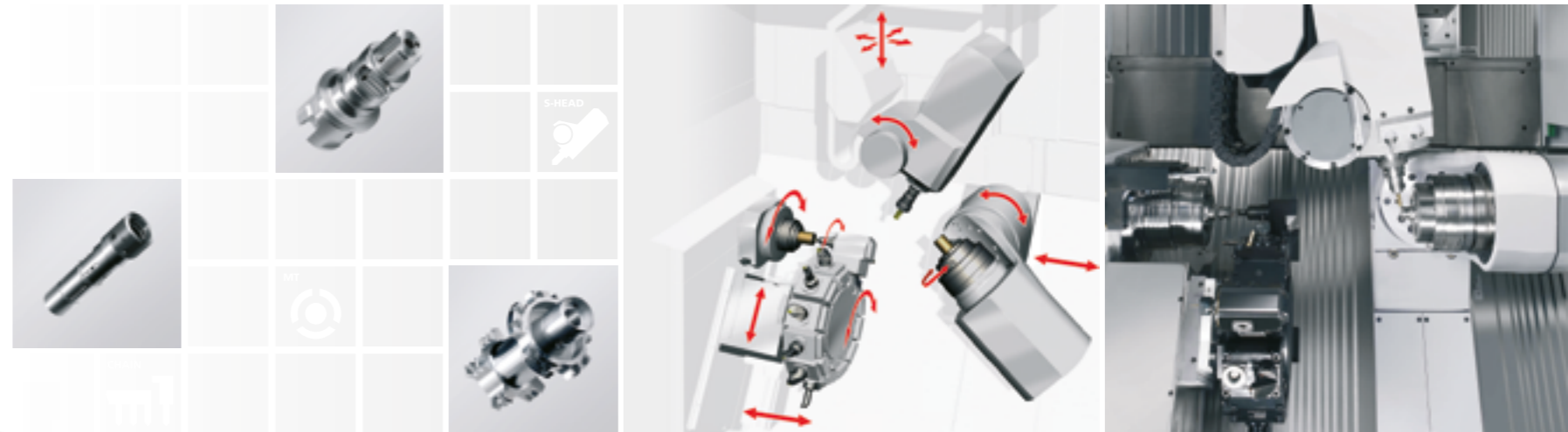
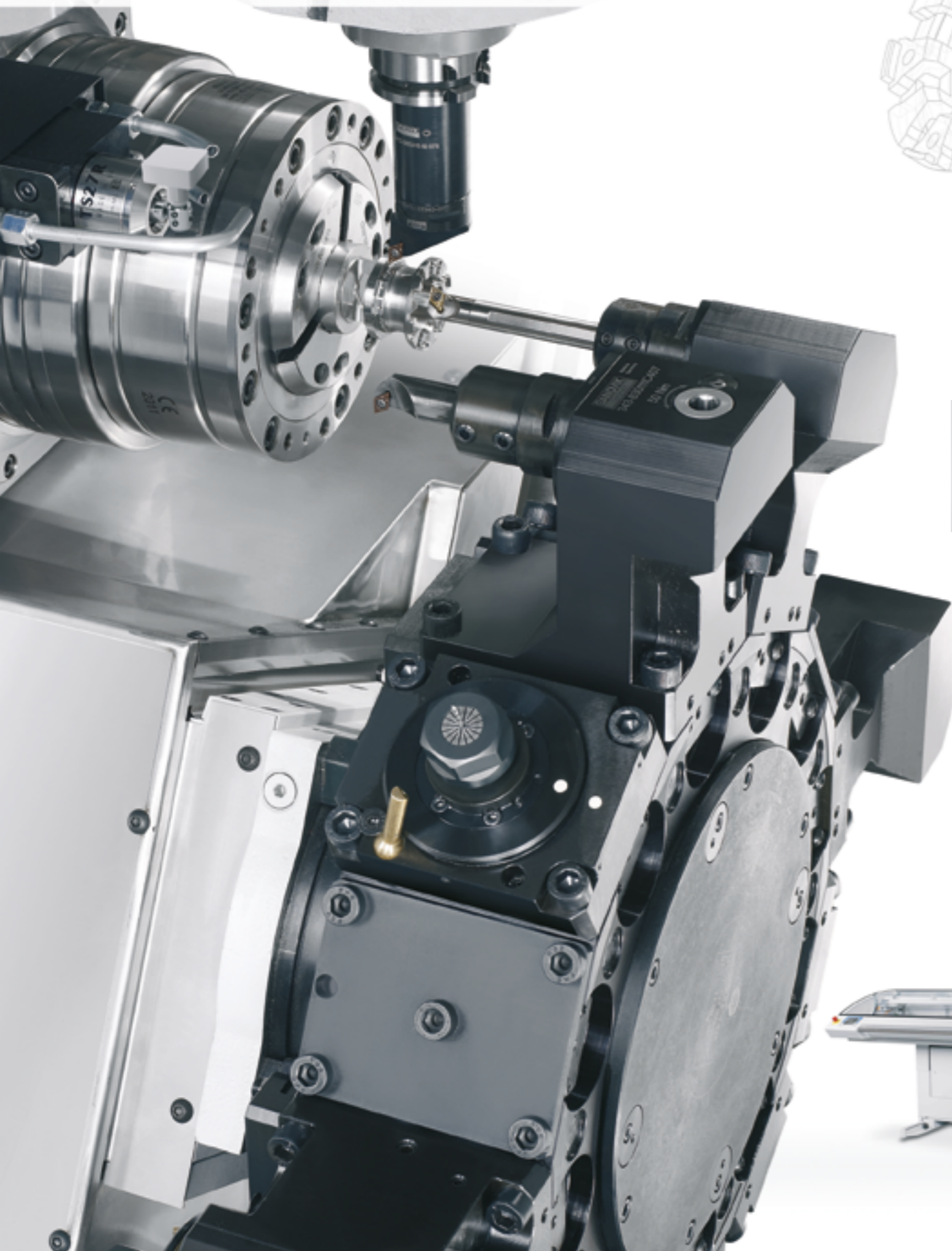

The modular design of the FZ12 MT enables customized configuration for its various applications in many industries.

Direct path-measuring systems on all (up to 10) axes and high-dynamic drives ensure top precision in positioning and simultaneous operation.

Your advantages with CHIRON MT:

- Simultaneous turning and milling in one machine
- High productivity through parallel machining functions
- Full-fledged turning function due to turning spindle (up to 8,000 rpm / IT6)
- Turning revolver with up to 12 driven tools (Capto C4)
- Reduction of the throughput time due to 6-sided complete machining from the bar (Passage up to 65 mm)
- Opposed spindle for rear-sided turning operations and 5-axis simultaneous milling
- Automatic tool change (main spindle) with the pick-up method
- Highly dynamic linear motors in the ZR and V axis
- Automatic tool change (main spindle) with the pick-up method with 24 / 48 / 64 tool places HSK 40 / HSK 50
- Mineral cast machine bed, high cutting capacity and precision
- Integrated finished part removal (chute, drawer)
- Compact installation area (width 2210 mm x depth 3510 mm)
- Machine tool construction "Designed and Made in Germany"



Turnkey customization completely from one source

Individual automation and engineered solutions for greater productivity

Variocell SYSTEM – Customized automation solutions:

- Machine-integrated spindle grippers
- Portal and articulated-arm solutions
- Load and unload devices
- Pallet changing systems
- Pallet storage for raw and finished parts
- Interlinked systems and much more



Variocell UNO

Machining center and robot cell as unit
Flexible and economical solution as a compact unit consisting of machining center, handling robot and workpiece storage unit for low-manpower operation and greater process reliability.

Integrated automation in the smallest area (< 1 sq. m), transported together, no separate set-up, no need for additional alignment of the robot cell or for more protective equipment.

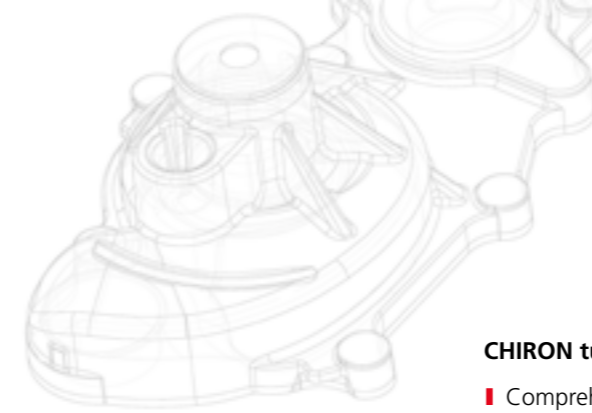
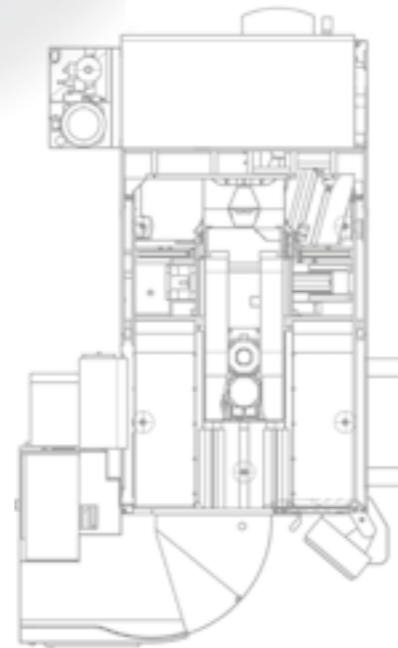

CHIRON turnkey solutions

- Comprehensive process design
- Expert engineering
- Experienced project management
- Validation of statistical process capability
- Ensuring targeted productivity
- Production support during the start-up phase
- Training in operation and programming
- CHIRON Service available around the world



Range of applications	[04–05]
Machine design	[06–07]
Extension options	[08–17]
▶ Services	[18–19]



From the planning stage to serial production

Today, manufacturing excellent machining centers alone is not enough. The user rightly expects a solution, which is as individual as it is intelligent. Starting from one specific machining task, a „Turnkey process“ is developed around the workpiece based on quantity structure and constraints. The CHIRON TURNKEY makes it possible to optimally solve complex tasks.

Together with perfectly adapted technology modules, CHIRON engineers create the most economical solution from one source to meet the customer’s special needs. This ensures decisive competitive advantages for CHIRON customers. CHIRON not only offers the machining solution itself, but also the support to keep manufacturing running at an optimal level.

CHIRON worldwide

Germany

CHIRON Werke GmbH & Co. KG
Kreuzstraße 75
78532 Tuttlingen, Germany
Tel. +49 7461 940-0
Fax +49 7461 940-53000
info@chiron.de
www.chiron.de

CMS-GmbH

Gewerbepark „take-off“ 125
78579 Neuhausen ob Eck, Germany
Tel. +49 7461 940-3700
Fax +49 7461 940-53701
cms@chiron.de
www.pre-owned-machines.com

France

CHIRON Technologies
de Production SAS
14 Chemin de la Litte
92390 Villeneuve-la-Garenne, France
Tel. +33 1 479 859 50
Fax +33 1 479 854 31
info@chiron-technologies.fr
www.chiron-technologies.fr

Italy

CHIRON Italia S.p.A.
Via Ambrosoli 4/C
20090 Rodano Millepini - MI, Italy
Tel. + 39 02 953 211 02
Fax + 39 02 953 286 20
info@chironitalia.it
www.chironitalia.it

Turkey

CHIRON Istanbul
Makine Ticaret ve Servis Ltd. Şti.
MURAT PAŞA MAHALLESİ ULUYOL
Caddesi No:19 İSTANBUL TOWER
Plaza Kat:13 D:59-60
34040 Bayrampaşa - İSTANBUL, Turkey
Tel. +90 212 612 12 11
Fax +90 212 612 48 28
info@chiron-turkey.com
www.chiron-turkey.com

Poland

CHIRON Polska Sp. z o.o.
ul. Darwina 42
44-177 Paniowki, Poland
Tel. +48 32 790 9850
info@chiron-poland.com
www.chiron-poland.com

USA

CHIRON America INC.
10950 Withers Cove Park Drive
Charlotte, NC 28278, USA
Tel. +01 704 587 95 26
Fax +01 704 587 04 85
info@chironamerica.com
www.chironamerica.com

Detroit Office
44692 Helm Street
Plymouth, MI 48170
Tel +01 734 233 9650
Fax +01 704 587 0485
info@chironamerica.com
www.chironamerica.com

China

CHIRON Machine Tool (Beijing) Ltd. China
Room 1805, NUO Office
A2 Jiangtai Road, Chaoyang District
Beijing 100016, PRC
Tel +86 10 6598 9811
Fax +86 10 6598 9812
info@chiron-china.com
www.chiron-china.com

CHIRON Machine Tools (Taicang) Co., Ltd.

No.1-1, Fada Road
Technological Development Zone,
Taicang 215413, Jiangsu Province
P.R. China
Tel. +86 512 5367 0800
Fax +86 512 5367 0808
info@chiron-china.com
www.chiron-china.com

India

CHIRON India Machine Tools
Private Limited
#33, Naseer Affinity , 1st Floor
Miller Tank Bund Road, Kaveriappa Layout
Vasanth Nagar, Bangalore - 560 052, India
Tel. +91 80 4905 6490
Fax +91 80 4905 6450
info@chiron-india.com
www.chiron-india.com



- Production, Sales & Service
- Sales & Service
- CHIRON Partner

CHIRON Group

chiron

STAMA

SCHERER
FEINBAU

CHIRON Werke GmbH & Co. KG

Kreuzstrasse 75
78532 Tuttlingen, Germany

Phone +49 7461 940-0
Fax +49 7461 940-53000